

GENERAL

1. Inspect compressor for shipping damage and file claim with shipping company if damaged or incomplete.
2. Check compressor nameplate for correct model and voltage designation.
3. Before installation, review all Carlyle compressor application literature to assure yourself that the proper compressor has been selected and is being applied in a proper manner. The required application literature is available through Carlyle.
4. To facilitate customer installation requirements, the following parts are factory supplied in a separate parts bag located in the compressor terminal box:

PART NUMBER	DESCRIPTION	QUANTITY
06EA500551	Jumper Bar (2 hole)	3
AT14QA241	Jam Nut 3/8	9
06EA502782	Jumper Bar (3 hole)	1
06EA402632	Tee Valve Assy.	1
574-068	Instruction Sheet	1

SAFETY INSTRUCTIONS

WARNING: Failure to follow these instructions could result in serious personal injury.

1. Follow recognized safety procedures and practices.
2. Do not remove any compressor bolts or fittings until factory-supplied holding charge has been relieved. Exhaust holding charge pressure through low-pressure connection (shown in Figs. 1 & 2) by removing the connection cap and depressing the internal disc.
3. Do not apply any power to the compressor unless suction and discharge service valves are installed and opened.
4. Do not operate or provide any electrical power to the compressor unless the terminal box cover is in place and secured. Measurement of amps and volts during running conditions must be taken at other points in the power supply.
5. Do not remove terminal box cover until all electrical sources have been disconnected.
6. Follow recommended safety precautions listed on terminal box cover label before attempting any service work on the compressor.

GENERAL INSTALLATION PROCEDURES

Holding Charge

Compressor is factory supplied with a 5 to 15 psig (1.4 to 2 bar) charge of dry air. This internal pressure must be relieved before attempting to remove any compressor fitting or part.

Relieve holding charge by removing the cap on the low pressure connection fitting and depressing the internal disc. See Figs. 1 & 2 for applicable low pressure connection fitting location.

Service Valves

Remove valve pads and attach factory supplied suction and discharge gaskets and service valves to the compressor. Torque applicable service valve mounting bolts as noted:

Bolt Size	Torque lb-ft (N-m)
5/16 - 18	19 - 23 (25.7 - 31.1)
1/2 - 13	80 - 90 (108 - 122)
5/8 - 11	90 - 120 (122 - 163)

When brazing piping to valve, disassemble valve or wrap in a wet cloth to prevent heat damage.

Oil

1. Check to see that oil level is 1/8 to 3/8 way up on compressor sightglass before starting and after 15 to 20 minutes of operation. Compressors may be shipped with or without an oil charge based on model. All compressors must contain the specified oil charge prior to start up as a condition of warranty.

CAUTION: Oil levels on 06E compressors should not be allowed to go above the center of sightglass. High oil levels require excess power and shorten compressor life.

2. To add oil: Relieve internal crankcase pressure, isolate crankcase, and add oil through the oil fill connection (see Figs. 1 & 2). To remove excess oil: Reduce internal crankcase pressure to 2 psig (1.15 bar), isolate crankcase then loosen the oil drain plug allowing oil to seep out past the threads of the plug.

CAUTION: With the compressor crankcase under slight pressure, do not remove the oil drain plug as the entire oil charge could be lost. Do not reuse drained oil or oil that has been exposed to the atmosphere.

3. When additional oil or a complete oil change is required, use only the listed Carlyle approved oils.

For CFC and HCFC refrigerants use:

Manufacturer	Brand Name
Totaline	150
Witco Suniso	3GS
Shrieve Chemical	Zerol 150
Texaco Ind.	WFI-32-150
IGI Petroleum Ind.	Cryol-150

For HFC refrigerants use:

Manufacturer	Brand Name
ICI EMKARATE	RL68H
*Lubrizol Lubrikuhl	2916S
**Mobil Arctic	EAL 68
**Castrol	SW 68
Castrol	E 68
Totaline	P903-1701

*Lubrizol ISO 68 also sold under Texaco Capella HFC 68NA brand

**Medium and high temperature applications only.

ELECTRICAL

General

Consult the wiring diagram located inside the compressor terminal box cover and Figure A for wiring connection locations.

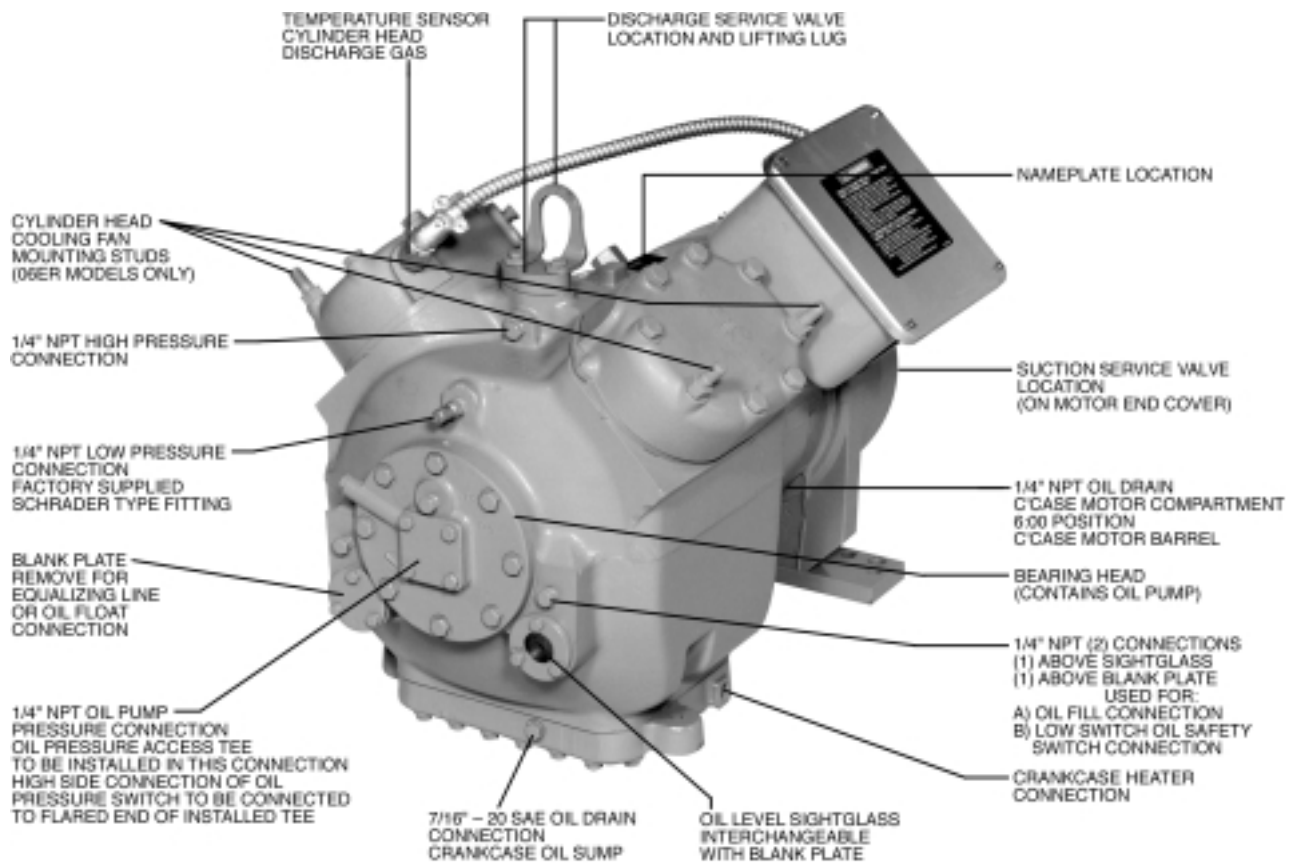

Figure 1
06E 4-Cylinder Compressor 50 Cfm (1.41 m³/m)

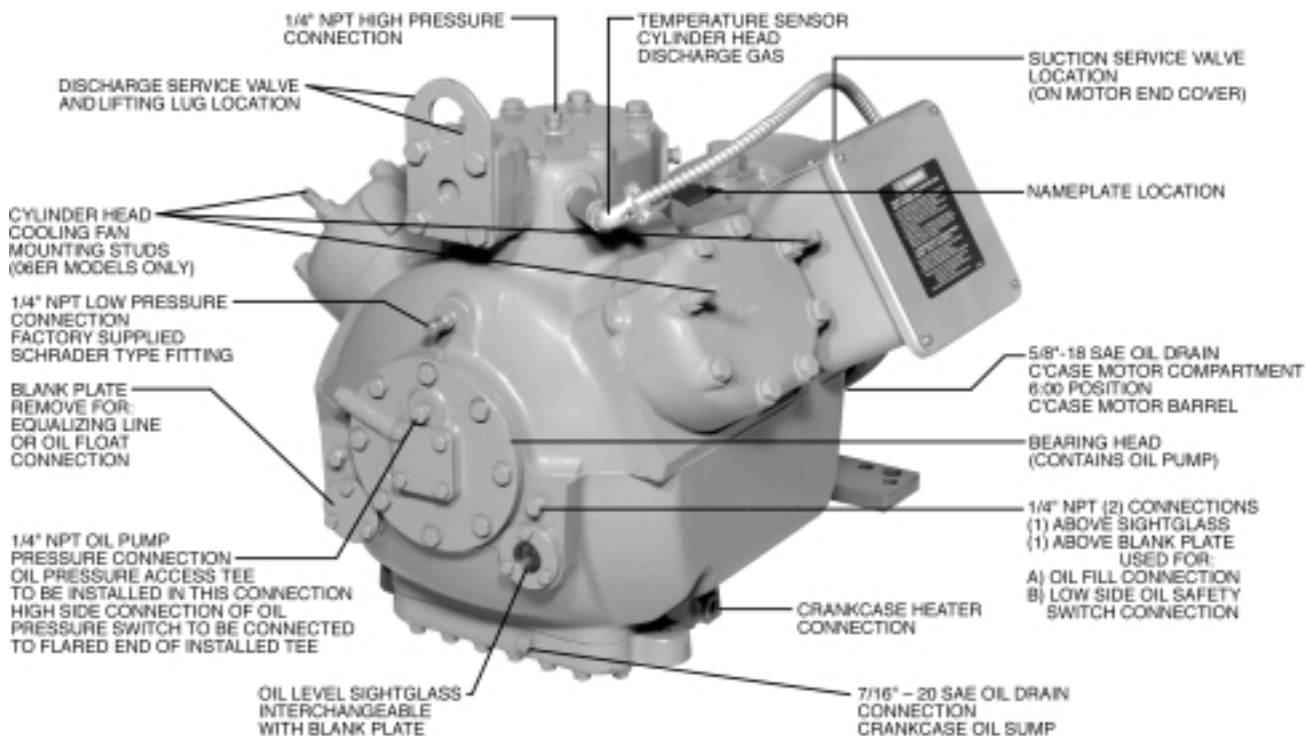

Figure 2
06E 6-Cylinder Compressor 65, 75, 99 Cfm (1.84, 2.12, 2.80 m³/m)

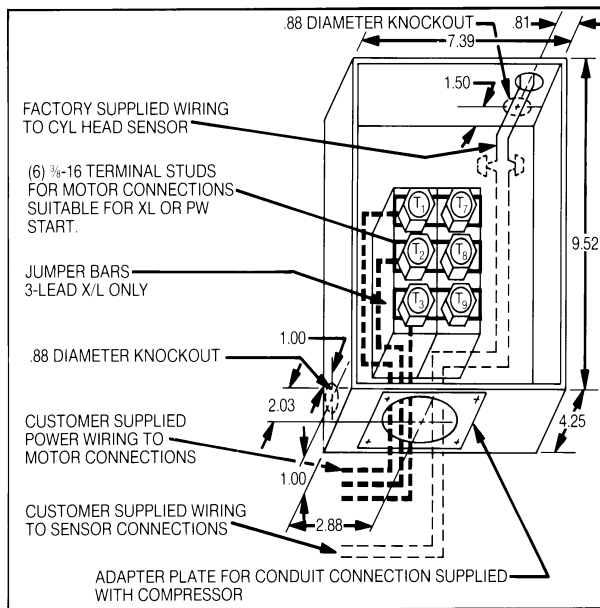

Figure A
Terminal Box Arrangement

TERMINAL BOX

The compressor terminal box is supplied with 2 support plates to mount the connector for the power wiring conduit. Select the one support plate with the opening suitable for the size of the conduit connector to be used and fasten it to the terminal box with the (4) screws provided.

TERMINAL PLATE WIRING

The parts listed in item #4 (General Comments, pg. 1) are supplied in parts bag with the compressor and are used when wiring the terminal plate.

Customer supplied wiring to the compressor terminal plate must be provided with insulated wire terminal connectors and be suitable for accommodating the 3/8" diameter terminal studs.

6-Pin Terminal Plate

3-Lead Across-the Line (X/L) Start (Fig. 3)

The (3) jumper bars supplied with the compressor are required for 3-Lead XL start only. Jumpers are assembled directly on terminal studs connecting T1 & T7, T2 & T8 and T3 & T9. The 3 power leads are to be assembled to the applicable terminal stud directly on top of the jumper bar. Secure wire terminals and jumper bars to the terminal studs with the (6) 3/8-16 jam nuts provided with the compressor. Torque jam nuts to 12 lb-ft (16 n-m) maximum.

6-Lead Part Winding (P/W) Start (Fig. 3)

The 6 power leads are to be assembled and secured to the applicable terminal studs with the (6) 3/8-16 jam nuts provided with the compressor. Torque jam nuts to 12 lb-ft (16 n-m) maximum.

Note: Jumper bars are not required with 6-Lead X/L or P/W start applications.

9-Pin Terminal Plate

208/230 V-3-60 or 200 V-3-50 Across-the-Line Start (Fig. 3)

1. Install (3) 2-hole copper jumper bars connecting terminals 1 to 7, 2 to 6, and 3 to 9.
2. Remove plastic connector block from terminals 4, 5 and 6.
3. Install the flat connector block (non-conducting) on terminals 4, 5 and 6.
4. Reinstall terminal nuts on terminals 4, 5 and 6 (removed in step #2).
5. Install the 3-hole copper jumper bar connecting terminals 4, 5 and 6.
6. Connect the line leads to terminals 1, 2 and 3.
7. Install (9) terminal nuts (included in this kit) on terminal studs to secure jumper bar/line connections. Tighten terminal nuts to 12 ft-lbs (16 n-m) maximum.

208/230 V-3-60 or 200 V-3-50 Part Winding Start (Fig. 3)

1. Remove plastic connector block from terminals 4, 5 and 6.
2. Install the flat connector block (non-conducting) on terminals 4, 5 and 6.
3. Re-install terminal nuts on terminals 4, 5 and 6 (removed in step #1).
4. Install the 3-hole copper jumper bar connecting terminals 4, 5 and 6.
5. Connect the line leads to terminals 1, 2, 3, 7, 8 and 9.
6. Install (9) terminal nuts (included in this kit) on terminal studs to secure jumper bar/line connections. Tighten terminal nuts to 12 ft-lbs (16 n-m) maximum.

460 V-3-60 or 400 V-3-50 Across-the-Line Start (Fig. 3)

1. Install (3) 2-hole copper jumper bars connecting terminals 7 to 4, 8 to 5, and 9 to 6.
2. Connect the line leads to terminals 1, 2 and 3.
3. Install (9) terminal nuts (included in this kit) on terminal studs to secure jumper bar/line connections. Tighten terminal nuts to 12 ft-lbs (16 n-m) maximum.

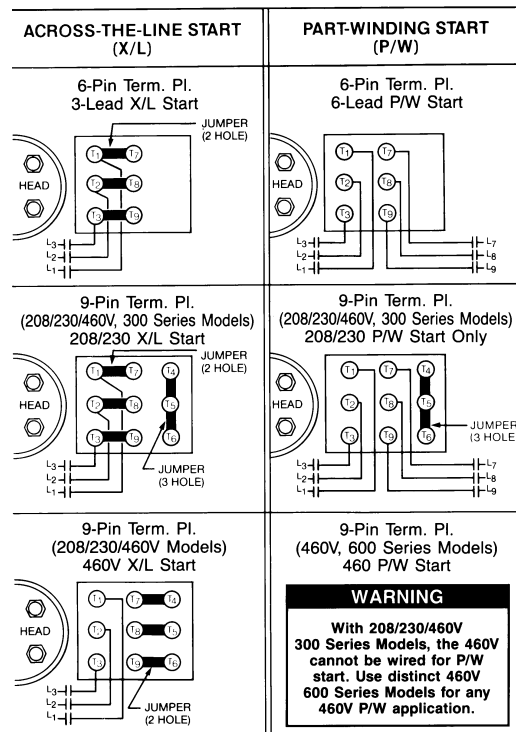

Figure 3
Terminal Plate Wiring

OIL PRESSURE SAFETY SWITCH

1. All Carlyle 06E compressors are provided with connections for an oil safety switch. The use of an oil safety switch can help prevent compressor failures when loss of lubrication or loss of compressor oil charge occur. The use of an oil safety switch is required as a condition of warranty for those 06E compressors which are applied on systems in which two or more 06E compressors are connected in parallel. On units in which single 06E compressors are applied, the use of an oil pressure switch is recommended. See Figs. 1 and 2 for oil safety switch connections.

2. Normal oil pressure for 06E compressors is 12 to 30 psi (.83 - 2.1 bar) above suction pressure. Select a switch to close the control circuit (at start-up) at a maximum of 12 psi (.83 bar) and open the control circuit at a minimum of 5 psi (.35 bar). A time delay of not less than 30 seconds nor more than 120 seconds is required for start-up purposes. The switch must also be manually reset when it trips.

3. The oil safety switch *high side connection* is to be attached to the oil pressure access tee which is field installed in the oil pump pressure connection (see Figs. 1 and 2). The *low side connection* of the oil safety switch is connected to the oil sump compartment of the crankcase (above the sight glass). See compressor pictorials (Figs. 1 and 2) for proper locations.

4. The following oil safety switches have been approved by Carlyle:

Carlyle Part No.	Time Delay	Connections	Pressure Diff. psi (bar)		Volts	Reset	Remote Alarm Circ Capability
			Cut In	Cut Out			
P529-2430	120 sec.	1/4" Male Flares	8-11 (.9-1.7)	4-8 (1.2-1.6)	115/230 (100/220)	Manual	Yes
P529-2410		3/8" Lg. Cap Tube 1/4" SAE Nuts					

Carlyle Part No.	Time Delay	Connections	Pressure Diff. psi (bar)		Volts	Reset	Remote Alarm Circ Capability
			Cut In	Cut Out			
06DA660115	120 sec.	Electronic	8-11 (.9-1.7)	4-8 (1.2-1.6)	115/230 (100/220)	Manual	Yes

OIL PRESSURE ACCESS TEE

1. The oil pressure access tee is supplied in a separate parts bag with the compressor and is to be installed in the oil pump above the oil pump cover.

CAUTION: Aluminum Bearing Head, Torque oil pressure access tee to 20 - 25 ft.-lbs (27 - 33 n-m)

2. The oil pressure safety switch high-side connection is to be attached to the opened flared end of the installed oil pressure access tee. The capped end of this tee contains a schrader type valve which permits access to the oil pressure while the compressor is operating.

MOTOR PROTECTION

Overcurrent Protection - Customer Supplied

1. 06E compressors are supplied "less" motor overcurrent protection devices. Compressor user *must* provide properly sized overcurrent motor protection. See application manual and price pages for specifications.

2. Carlyle recommends the use of calibrated circuit breakers. Circuit breakers based on X/L start with trip settings selected for proper compressor motor size and voltage are available from Carlyle.

Over-Temperature Protection - Factory Supplied

A discharge gas thermal sensor is factory installed in the cylinder head on all new 06E compressors. The temperature of the discharge gas in the high stage cylinder head is monitored by the thermal sensor. If the discharge gas temperature at the sensor exceeds its maximum limit (see 06D/E application guide for limits), the sensor will open the control circuit and shut off the compressor. The (2) sensor wire leads (#16 AWG, stripped back 1/2") (1.27 cm), located in the compressor terminal box are to be connected in series in the unit control circuit wiring. The discharge temperature sensor operates as an automatic reset device; however, Carlyle recommends that it be wired in the control circuit in a manual reset mode (see 06D/E application guide for wiring diagram). Since the cylinder head sensor would help prevent many of the failures caused by overheating, the best control method would be to determine the cause and correct the reason for overheating when the initial sensor trip occurs.

COOLING FANS

Cylinder head cooling fans are recommended for saturated suction temperature (SST) below 0°F (-18°C) and are required based on SST as follows:

Refrigerant	SST
R-22	0°F (-18°C)
R-507/404A	-25°F (-32°C)

Manufacturer reserves the right to discontinue, or change at any time, specifications or designs without notice and without incurring obligations.

Carlyle Compressor Co. • © Carrier Corporation (Rev. C 07/02)
P.O. Box 4808, Syracuse, NY 13221
Phone: In US & Puerto Rico 1-800-GO-CARLYLE
In Canada 1-800-258-1123
In Mexico 001-800-462-2759

Lit. No. 574-068
Replaces 06EA501602